Alber Training and Education Product Tutorial

Battery Monitoring Theory and
Ohmic Measurement Methods





Tutorial Topics

- The Value of Monitoring
- Capacity Test vs. Resistance Test
- Ohmic Measurement Methods
- Measurement Resolution
- Noise and AC vs. DC Measurements
- Auto-logging Discharges and Playback
- Resistance Increases in Multi-cell Units

Tutorial Topics - continued

- Multi-cell and Single Cell Replacement Guidance Criteria
- The Alber Advantage
- More Tutorials

Value of Monitoring

- Avoiding Battery Failure
- Monitoring including DC resistance tests allows for early detection of weak cells so they can be replaced before they risk integrity of the string
- Optimize Useful Battery Life
 - The monitor will provide information about parameters that affects battery life, allowing for corrective actions and maximal useful life.
- Safety
 - By avoiding catastrophic failures and automatic measurements and minimizing risk exposure, safety is increased

Capacity Testing vs. Resistance Testing



Capacity Testing

- An off-line discharge test using load bank with constant current capability while continuously monitoring each battery cell voltage to identify the bad cells
 - **Time consuming** (1 to 10 hours plus recharge time)
 - **Requires external load** bank and backup battery in some cases
 - + **Reliable** - The only way to truly assess the battery's absolute capacity



Resistance Testing

- A condition test measuring the internal resistance of each battery cell. As battery condition declines, the resistance increases. Increased internal resistance indicates aging or premature failure before the cell cause critical failure to the battery.
 - + **On-line, non-invasive** test that can be performed manually or automatically
 - **Does not provide an absolute capacity** value and chemical problems are more difficult to detect at an early stage



Cell Resistance vs. Capacity

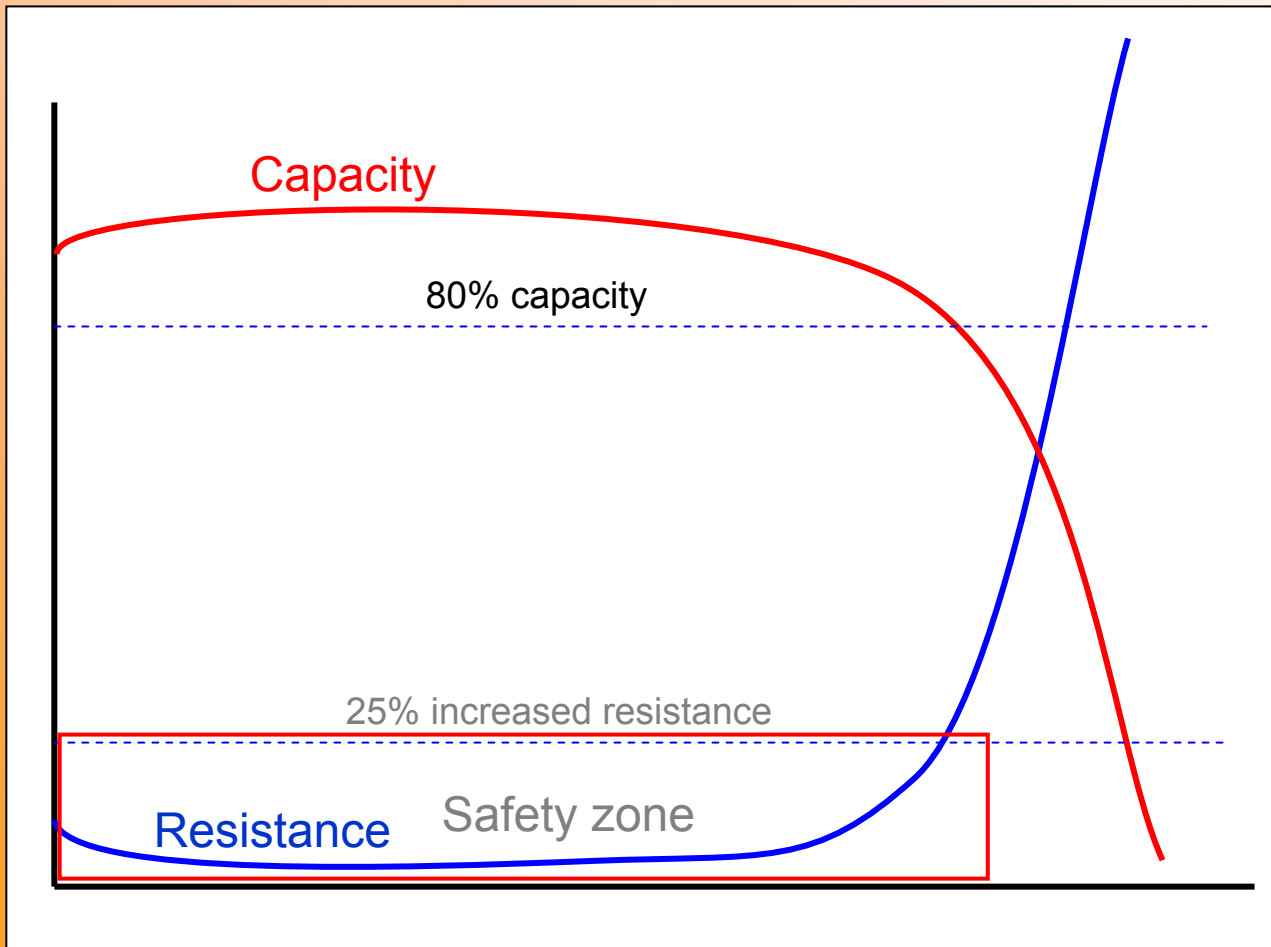

It is a fact that when cell resistance **increases**, capacity **will decrease**

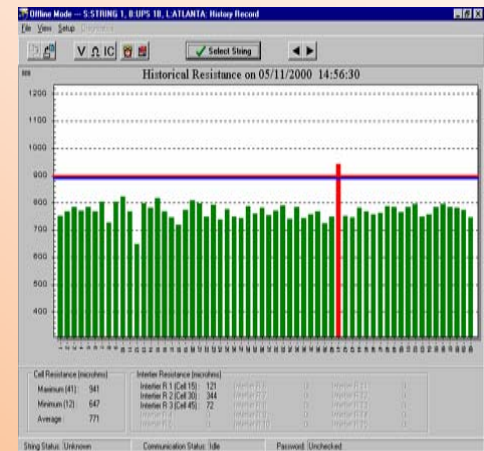

Ohmic Measurements

- The following terms are used in the battery industry to describe internal ohmic measurements
 - AC Impedance (Z) (B-tech, MEGGER, Polytronics, Enersafe...)
 - AC Conductance (Siemens) (Midtronic)
 - Resistance (NDSL/Cellwatch)
 - DC Resistance (Alber)

But this is only the presentation of the data. *It is the way the measurement is made that dictates the accuracy and bearing of the test*

AC Testing Method

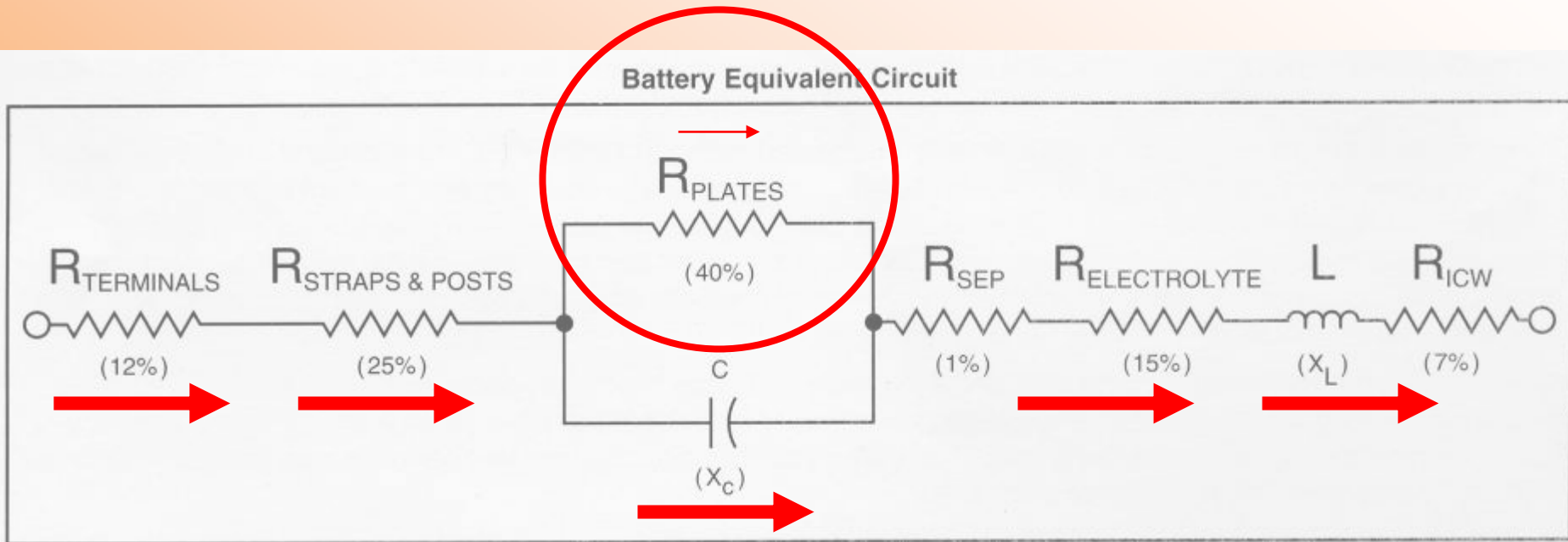

AC testing is an abnormal battery condition. When AC load is applied, most of the current will pass through the capacitor. Test frequency and size of capacitor will define the amount of current passing through the capacitor instead of the plates.

DC Resistance Measurements

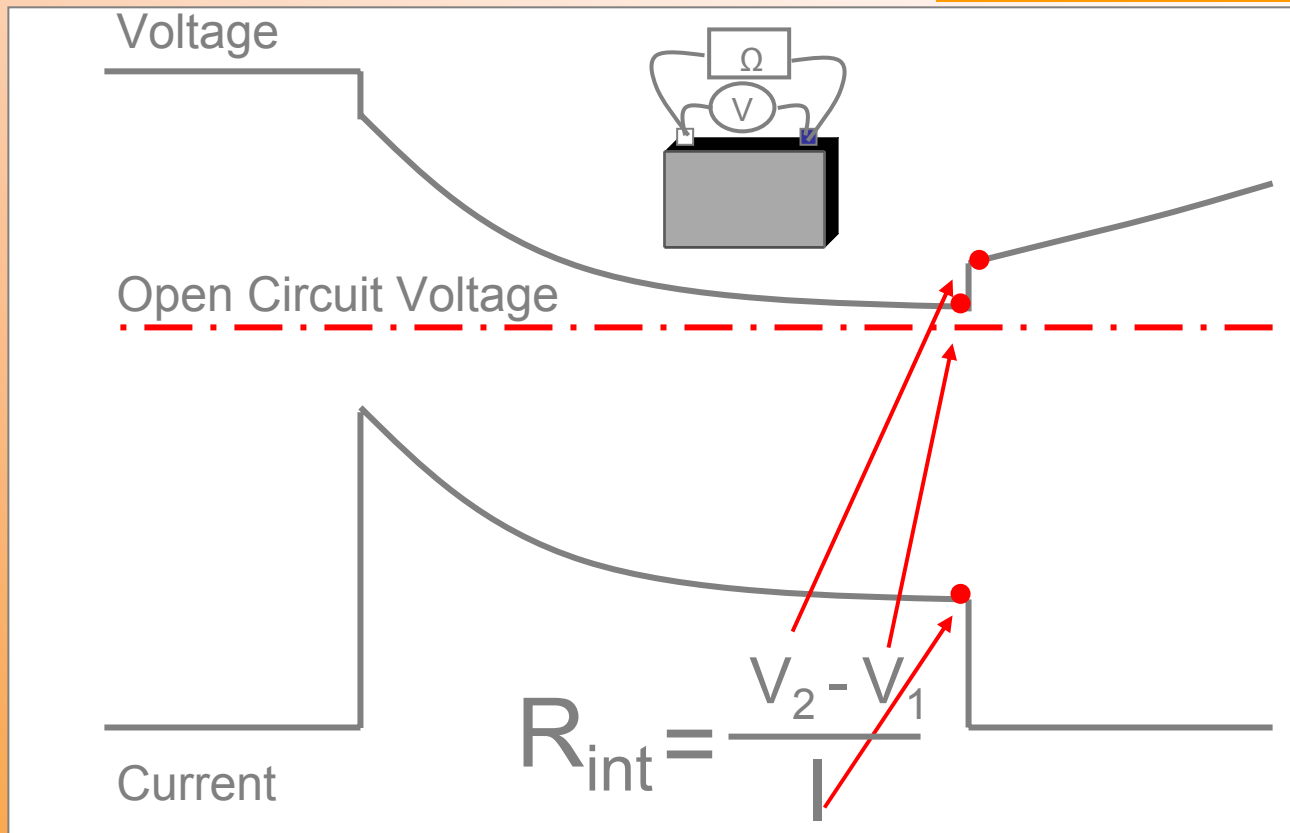

Test current is disconnected before the battery voltage reaches the open circuit voltage level.

No electro chemical reaction and no loss of capacity.

Test Current and Resolution

- The difference in resistance between a good and bad cell is 25%
- Example: A 1000Ah cell has $200\mu\Omega$ resistance. $25\% = 50\mu\Omega$
- In order to accurately measure this difference the resolution of the test equipment should be 10% of the critical value ($50\mu\Omega$)
- $50\mu\Omega * 10\% = 5\mu\Omega$
- Alber uses test currents from 20-30 amps, which requires a measurement of 1.5mv
- Most competitors use a 1 amp test current requiring a measurement of 50uv.
- Alber resolution is 20-30 times greater

Required resolution

Difference between good and bad $50\mu\Omega$

New Battery $200\mu\Omega$

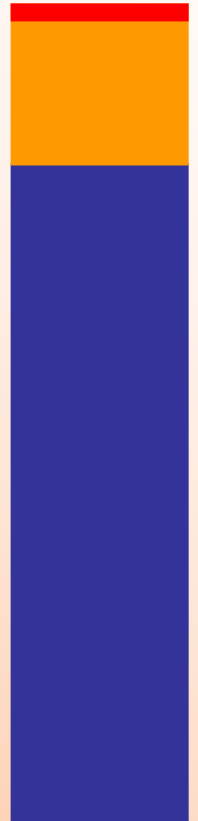

Noise and AC Measurements vs. DC Measurements

- Low AC test signal will “disappear” in UPS AC noise
- Trending data will typically change when noise changes due to load or failing capacitors on UPS
- The Alber DC test method is not affected by ripple

Typical ripple

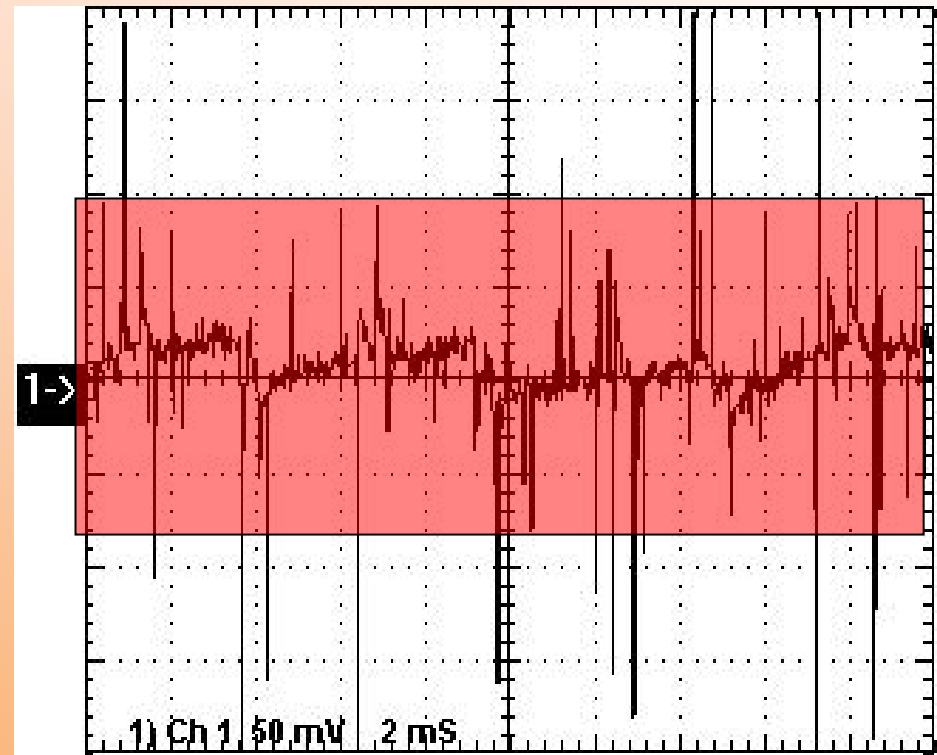

Complete Monitoring is Required

- Increased resistance will reveal the weakest link
 - An resistance increase of approximately 25% in one 2 volt cell is enough to fail a complete battery string
 - 12 volt VRLA monoblocks are more susceptible to this increase because 6 cells must be measured as one unit
- Monitoring **overall voltage** is not enough
- Monitoring **cell voltage** will not detect a bad cell
- **Partial discharge** tests will not detect all faults
- Individual cell voltage monitoring is important during discharge tests

Automatic Discharge Logging and Playback

- The following data were provided by an Alber customer from a battery that experienced an 18 minute discharge
- UPS system
- Battery – 60, 4 cell units – 240 cells
- Load – Approximately 930 amps
- Battery power – 223, 000 watts



809

Historical Resistance on 05/11/2000 14:56:30

Note unit #41 and the high resistance. The next screen clearly illustrates how the battery performed under actual discharge conditions.

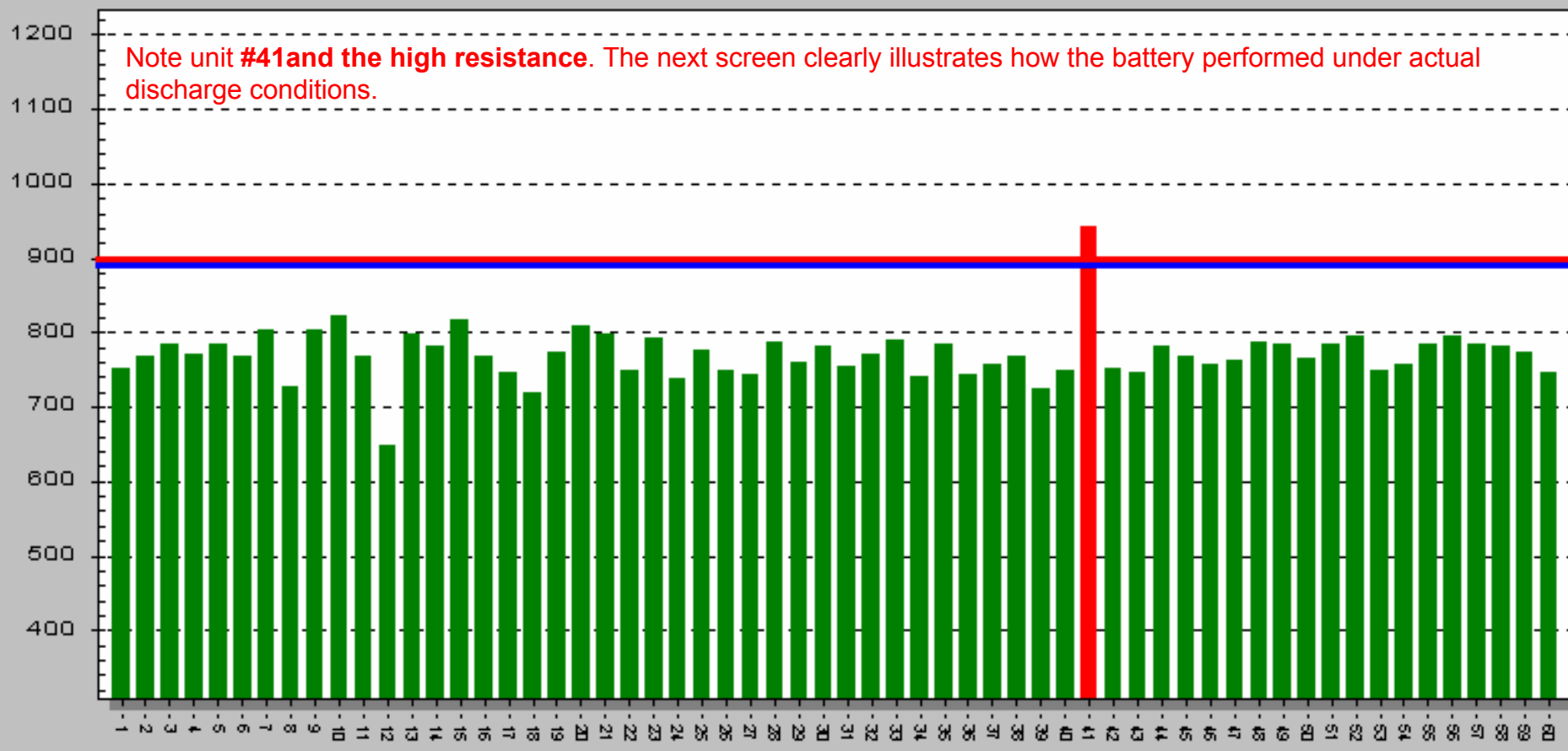

Cell Resistance (microhms)	
Maximum (41):	941
Minimum (12):	647
Average:	771

Intertier Resistance (microhms)					
Intertier R 1 (Cell 15):	121	Intertier R 6:	0	Intertier R 11:	0
Intertier R 2 (Cell 30):	344	Intertier R 7:	0	Intertier R 12:	0
Intertier R 3 (Cell 45):	72	Intertier R 8:	0	Intertier R 13:	0
Intertier R 4:	0	Intertier R 9:	0	Intertier R 14:	0
Intertier R 5:	0	Intertier R 10:	0	Intertier R 15:	0

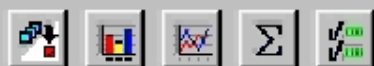

Replay forward

Starting Time: 10:38:04

Ending Time: 10:56:08

Time Interval: 01:00

Elapsed Time: 00:01:00

Overall Voltage (V): 453.5

Discharge Current (A): 903

Cell Voltage (V)

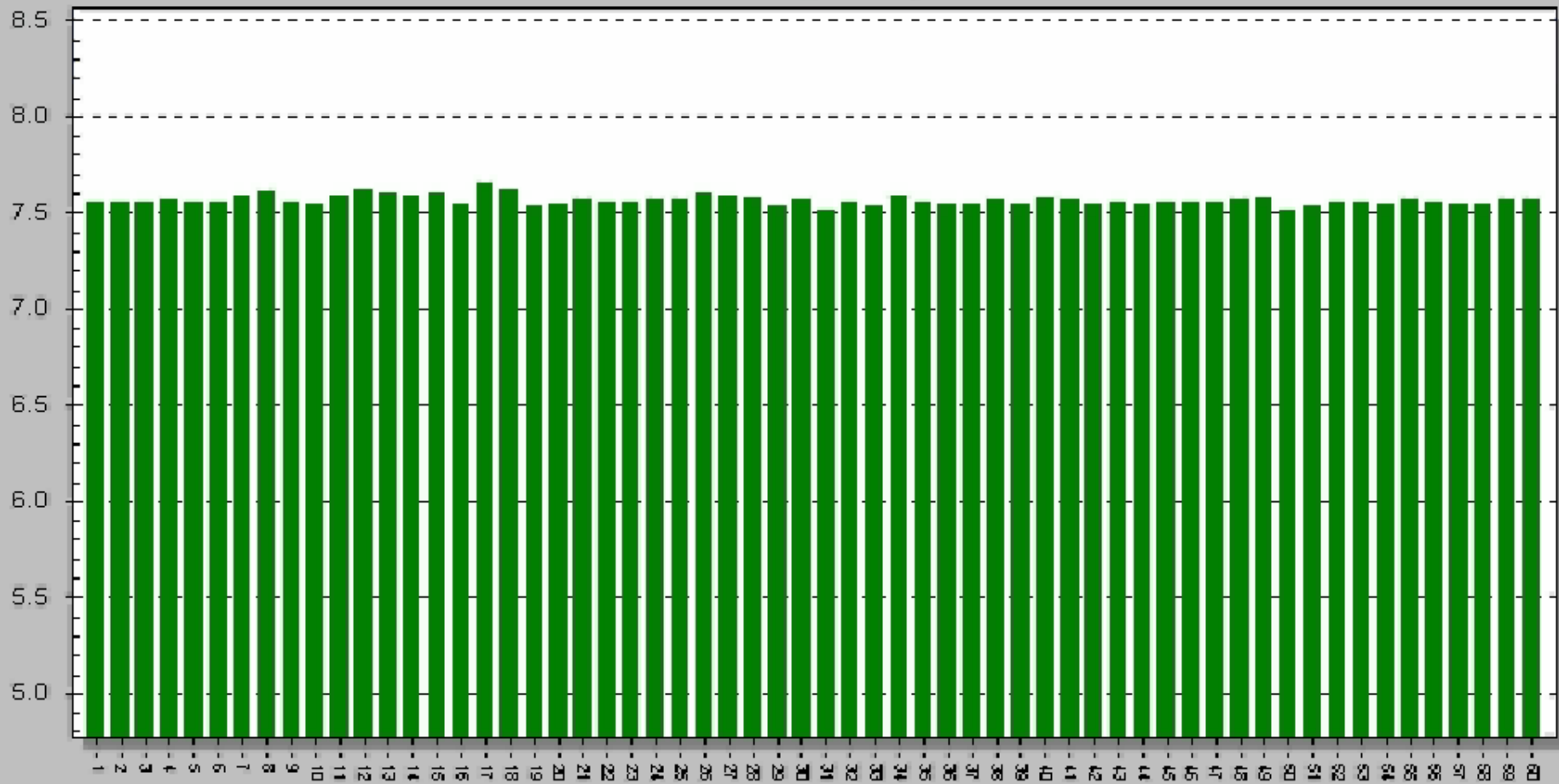

Communication Status: Unknown

New Data: No New Data

Sort: End Date/Time (D)

Discharge Playback

- The discharge playback clearly illustrates the need for a battery monitor to be able to detect a discharge, capture all cell data and make it available for viewing and analysis
- Without a resistance measurement to indicate a problem, early detection without having a discharge would be impossible because the float voltage of the unit was within normal specification

Discharge Playback

- It is also noteworthy, had the discharge continued and the unit reversed polarity, it is possible battery voltage would have collapsed, dropping the load
- The failed multi-cell unit also could have failed catastrophically, leaving the battery unavailable until repairs could be made
- System integrity would be lost

Resistance Increases in Multi-cell Units

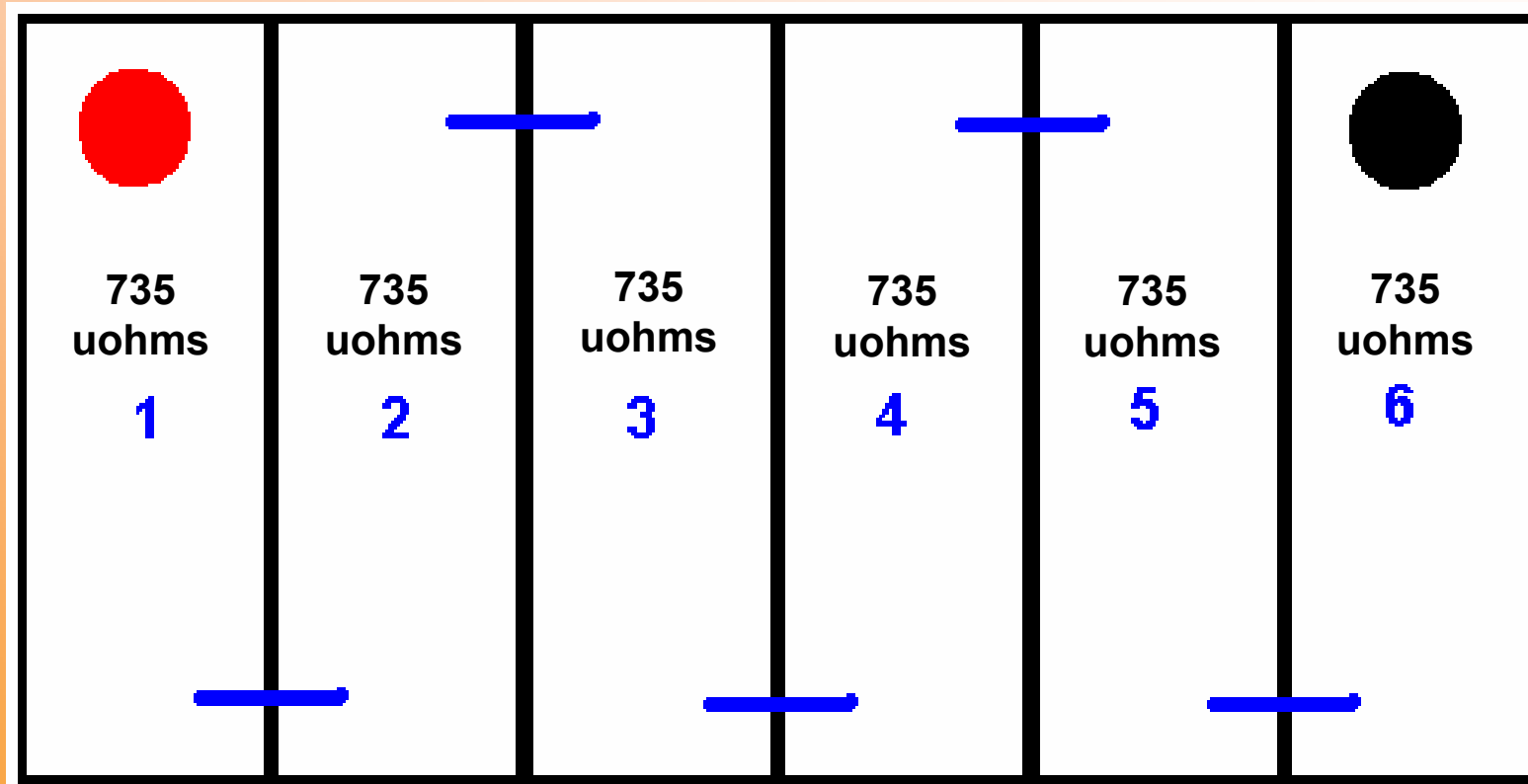

**12V, 150 AH VRLA Monoblock
4400 Micro-Ohms**

Failure of One Cell – Typical of VRLA

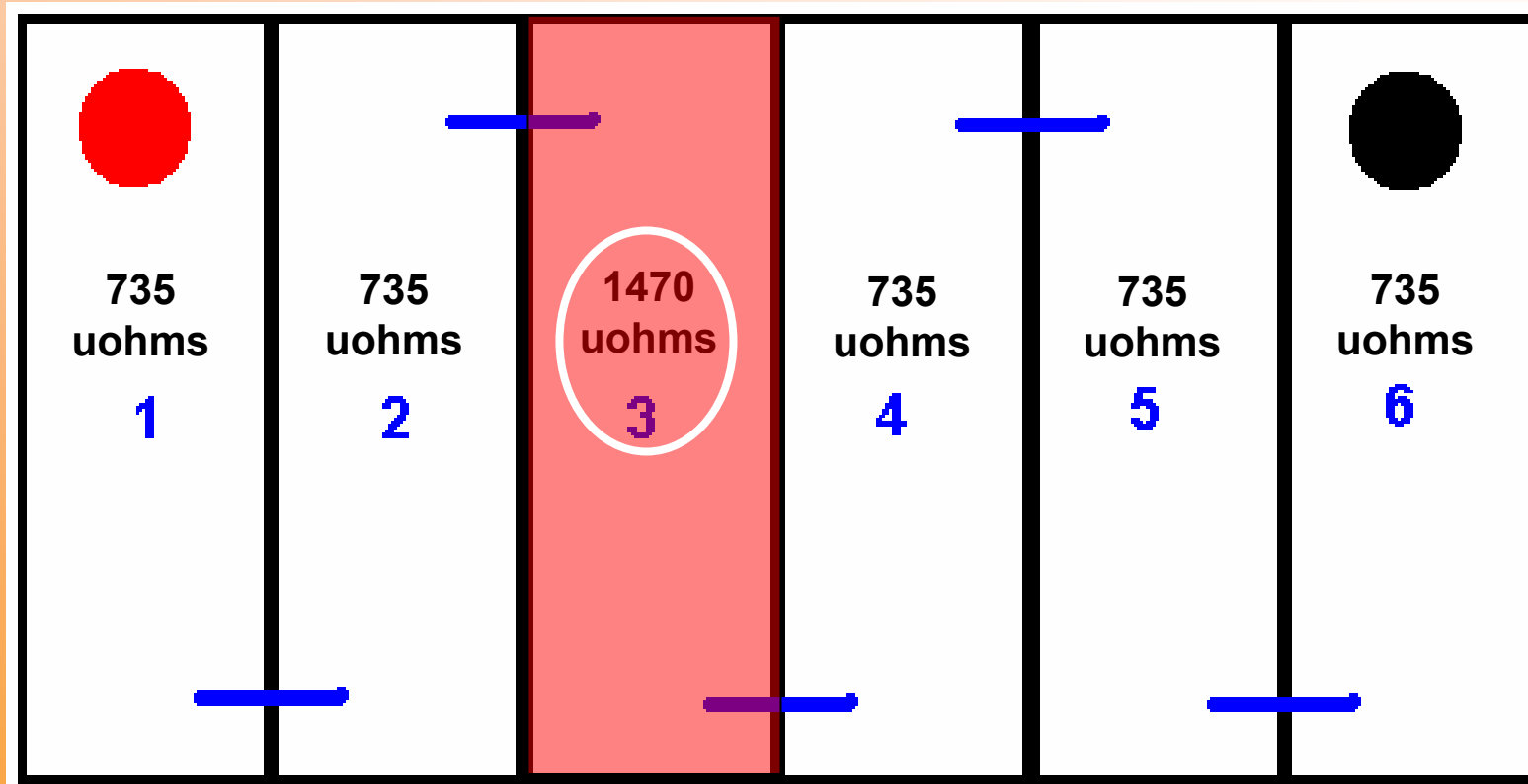

**12V, 150 AH VRLA Monoblock
Now 5135 Micro-Ohms**

Failure Example

- A 6 cell monoblock measures 4400 micro-ohms when new
- This is an average of 735 micro-ohms per cell
- One cell doubles in resistance to 1470 micro-ohms
- Overall unit resistance increases to 5135
- This is an overall increase of only 15%
- Waiting for this module to increase to 5500 micro-ohms (25%) or higher without testing or replacement would be a mistake

Multi-cell Unit Tolerance Recommendations

- These configurations should have tighter tolerances on allowable resistance increases
- The resistance of a single cell cannot be measured due to its construction
- Alber recommends a **10-15% maximum increase from installation baseline values**
- *We recommend a continuity test at a minimum or replace the unit*

Individual Cell Tolerance Recommendations

- **Individual Cells – 2v**
- **Replace any cell** whose internal resistance reading is greater than 50% above its installation baseline without any further testing
- **Capacity test any cell** or string with resistance between 20-50% of baseline

The Alber Advantage

- Alber's technology is developed based on:
 - Our experience and knowledge about how batteries fail
 - Always comparing capacity tests with resistance tests
- Alber's technology addresses the three most important battery testing obstacles
 - The capacitor effect
 - The noise problem
 - Resolution requirements

Technical Assistance

- Product support is available Monday-Friday, 8:00a.m.-5:00p.m. ET
- Main Phone – 954-623-6660
- Email support – support@alber.com
- Web – www.alber.com
 - Downloads
 - User manuals
 - Installation instructions
 - Product literature and more
 - Service Bulletins

More Tutorials from Alber

- Please visit our website at www.alber.com/training for additional tutorials about monitoring products and software
 - Battery monitoring theory
 - Monitoring system basics
 - BDS-40 monitor
 - BDS-256 monitor
 - MPM-100 monitor
 - Battery monitor data manager software